

Medos



www.medos.pl



PL

Grupa Medos zajmuje się produkcją akcesoriów do stolarki otworowej już od ponad 20 lat. Nasza pasja i zaangażowanie sprawia iż wciąż rozwijamy się i wprowadzamy coraz większą gamę produktów. Aktualnie na polskim rynku zaopatrujemy ponad 80% rodzimych producentów stolarki PCV i Aluminium, a nasze produkty znaleźć można w ponad 60 krajach Europy, Azji oraz Ameryki Północnej i Południowej.

Obecnie zatrudniamy blisko 600 osób. Trzon naszej produkcji stanowi nowoczesna odlewnia stopów aluminium oraz ZnAl, wtryskownia tworzyw sztucznych, malarnia proszkowa, galwanizernia, anodownia, tłocznia oraz obróbka mechaniczna stali i aluminium. Cały proces projektowania nowych produktów realizowany jest w naszej firmie, a wszystkie narzędzia wykonujemy we własnej narzędziowni.

Ciągłe poszukiwanie innowacyjnych rozwiązań i produktów, nowoczesna technologia, szybka realizacja zamówień, orientacja na klienta, profesjonalna i efektywna załoga, wysokie standardy i przywiązywanie uwagi do każdego szczegółu to fundament naszej firmy.

Dołącz do nas, razem otworzymy drzwi do sukcesu!

EN

Medos Group has been manufacturing accessories for doors and windows for over 20 years. Our passion and commitment help us grow and introduce new range of products. Right now we supply more than 80% of Polish producers of PVC and aluminum, and our products can be found in more than 60 countries in Europe, Asia and South America.

Currently we employ around 600 people. The core of our production is a modern aluminum alloy and Zamak die casting foundries, plastic injection molding, powder coating, galvanizing and anodizing plant, machine pressing and machining of steel and aluminum. The whole process of designing new products is undertaken in our company, and all of the tools are made in our own tool shop.

Continuous research for innovative solutions and products, modern technology, fast execution of orders, customer orientation, professional and efficient staff, high standards and meticulous attention to detail is the foundation that we build our company upon.

Join us, together we will open the door to success!

FR

Le Groupe Medos fabrique les accessoires pour menuiserie depuis plus de 20 ans. Notre passion et engagement nous font développer et introduire toujours de nouveaux produits. Actuellement, nous sommes fournisseur pour 80% de fabricants de menuiserie PVC et aluminium en Pologne et nos produits se vendent dans 60 pays en Europe, Asie, Amérique du Nord et du Sud.

En ce moment notre effectif compte plus de 600 salariés. Notre production est concentrée autour d'une fonderie d'alliages d'aluminium et de ZnAl moderne, des ateliers d'injection, de peinture à poudre, de galvanisation, d'anodisation, d'estampage, et d'usinage d'acier et d'aluminium. Le processus de conception de nouveaux produits est entièrement réalisé au sein de notre société.

Recherche constante de solutions et de produits innovants, technologie moderne, réalisation rapide de commandes, concentration sur le client, équipe professionnelle et efficace, standards élevés et attachement aux détails – voilà les fondements de notre société.

Rejoignez-nous!

RU

ГК «Medos» занимается производством фурнитуры для окон и дверей уже более 20 лет. Увлечение своим делом и оперативность действий помогают нам развиваться и вводить новую гамму продуктов. В данный момент мы снабжаем более 80% польских производителей окон и дверей из ПВХ и алюминия, а наши изделия можно найти в более 60 странах Европы, Азии, а также Северной и Южной Америки.

У нас работает более 600 человек. Основой нашего производства являются современный литейный цех (производство изделий из алюминия и сплава цинка), литейный цех по производству пластмассы, цех порошковой покраски, гальванический цех, цех по анодированию, пробивные прессы и механическая обработка стали и алюминия. Весь процесс от проектирования до внедрения новых изделий осуществляется в нашей фирме, а все пресс-формы выполняются в отделе по разработке и конструированию деталей.

Постоянный поиск инновационных решений и новых продуктов, современная технология, быстрая реализация заказов, ориентация на потребителя, профессиональный и эффективный коллектив, высокие стандарты обслуживания и внимание к деталям – это фундамент нашей фирмы.

*Приглашаем к сотрудничеству,
вместе мы откроем дверь к успеху!*

Spis treści

Index / Table des matières / Содержание

Pochwyty ze stali nierdzewnej

INOX pull handles / Barre de tirage en INOX / Офисные ручки INOX

4-5	SS
6-7	SS9005S
8-9	SS40
10-11	SS40M
12-13	SP
14-15	CS
16-17	MA
18-19	SE
20-21	WB
22-23	CW
24-25	PR
26-27	PR9005S
28-29	KW

Pochwyty aluminiowe

Aluminium pull handles / Barre de tirage en aluminium / Алюминиевые офисные ручки

30-31	Paris
32-33	Lisbon
34-35	Madrid
36-37	Prostokątny / Rectangular / Rectangulaire / Прямоугольная
38-39	Trójkątny / Triangular / Triangulaire / Треугольная
40-41	Prosty / Straight / Droit / Прямая
42-43	Owalny / Oval / Ovale / Овальная

44-47 Szyldy drzwiowe

Door rosette / Rosace / Накладка под цилиндр

Mocowania do pochwytów

Fixing sets / Ensembles de fixation / Крепежные наборы

48-49	ze stali nierdzewnej Stainless steel / en INOX / из нержавеющей стали
50	aluminiowych Aluminum / en aluminium / алюминиевых

Medos



SS



-N^o: 114SS30050045

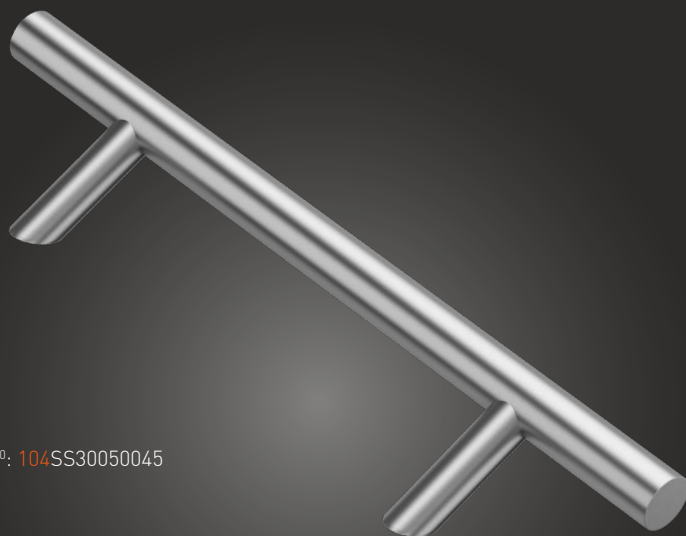

-N^o: 104SS30050045

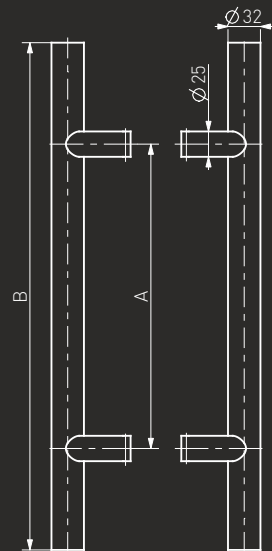

A	B
300	500
400	600
450	650
600	800
800	1000
1000	1200
1200	1400
1200	1600
1300	1800

45°

90°

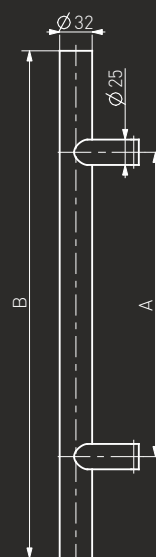
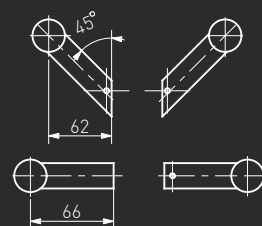

Pochwył na wymiar
Custom Sized Stainless Steel Pull Handles
Poignées de tirage inox sur mesure
Офисная ручка под размер



Dostępne w stali nierdzewnej 316
Available in 316 stainless steel
Disponibile en acier inoxydable 316
Доступные в типе нержавеющей стали 316



Pochwył wymaga okresowej konserwacji
Pull handle requires periodic maintenance
Poignée de tirage exige une conservation régulière
Офисный хват требует регулярного ухода

Pochwył ze stali nierdzewnej "SS" (INOX)

Szczotkowany / Brushed / Brossée / Шлифованная

Pochwył drzwiowy / Pull handle / Barre de tirage / Офисная ручка

Medos



SS9005S



-Nº: 2x 104SS300500459005

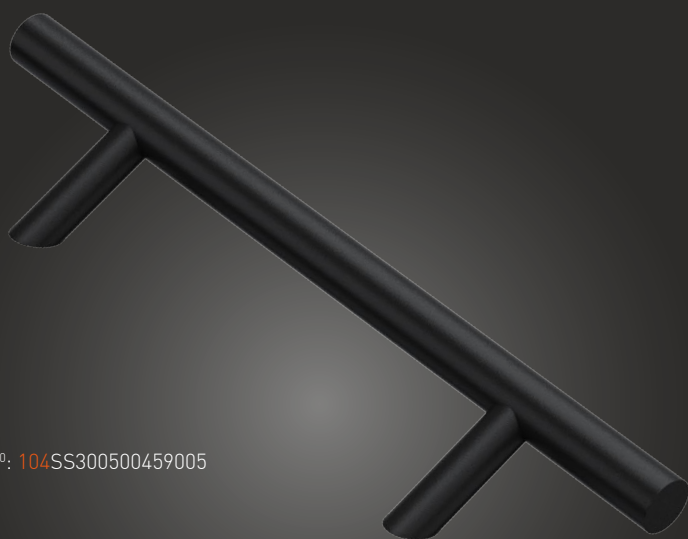

-Nº: 104SS300500459005

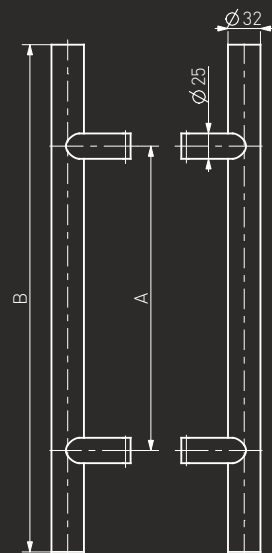

45°

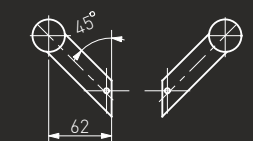

90°



A	B	∠
300	500	45°, 90°
600	800	45°
800	1000	45°
1000	1200	45°
1200	1400	45°
1300	1800	45°

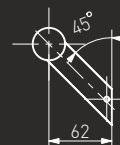
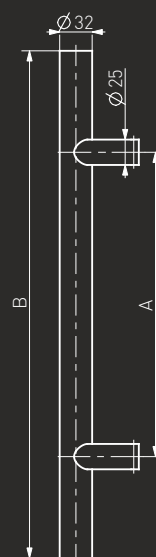

Pochwył ze stali nierdzewnej "SS9005S" (INOX)

Lakierowany / Varnished / Laqué / Лакированный

Pochwył drzwiowy / Pull handle / Barre de tirage / Офисная ручка

Medos



SS40



-N°: 114SS401000120045

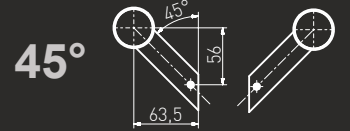
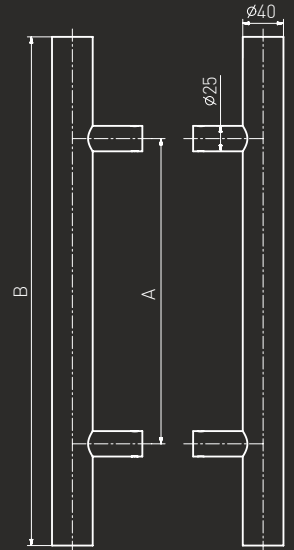

A	B
1000	1200
1200	1400
1200	1600
1300	1800
1800	2000
2000	2200

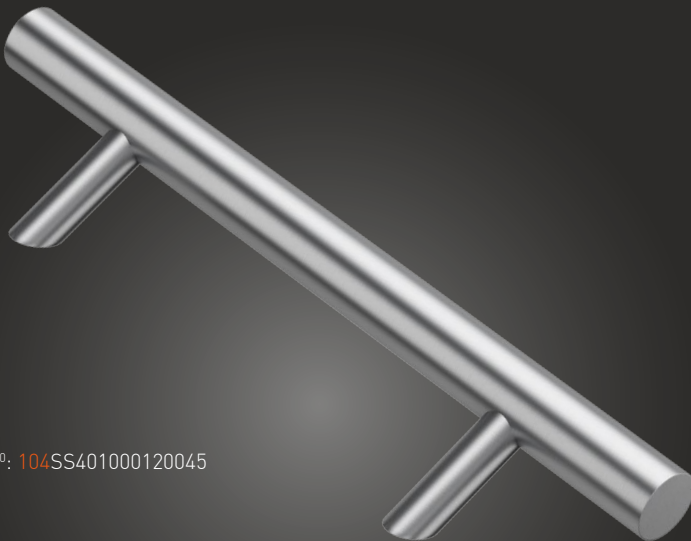

-N°: 104SS401000120045

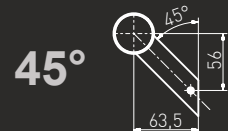
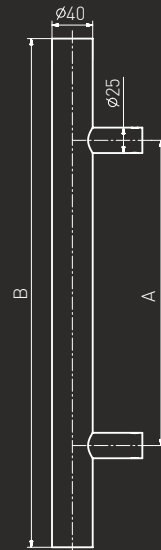

Pochwył na wymiar
Custom Sized Stainless Steel Pull Handles
Poignées de tirage inox sur mesure
Офисная ручка под размер



Pochwył wymaga okresowej konserwacji
Pull handle requires periodic maintenance
Poignée de tirage exige une conservation régulière
Офисный ухват требует регулярного ухода

Pochwył ze stali nierdzewnej "SS40" (INOX)

Szczotkowany / Brushed / Brossée / Шлифованная

Pochwył drzwiowy / Pull handle / Barre de tirage / Офисная ручка

Medos

SS40M

17





-N^o: 2x 104SS40M206210090

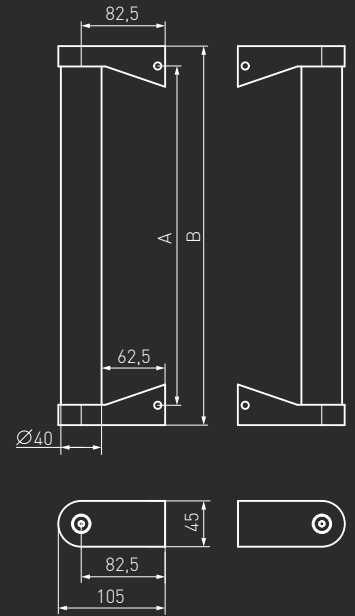

A	B
2061	2100
2261	2300
2461	2500



-N^o: 104SS40M206210090

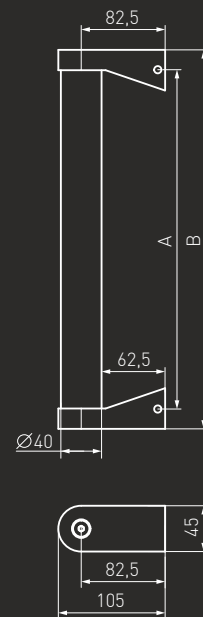

Instrukcja montażu
Assembly instruction
Instructions de montage
Инструкция по монтажу



Pochwył wymaga okresowej konserwacji
Pull handle requires periodic maintenance
Poignée de tirage exige une conservation régulière
Офисный ухват требует регулярного ухода

Pochwył ze stali nierdzewnej "SS40M" (INOX)

Szczotkowany / Brushed / Brossée / Шлифованная

Pochwył drzwiowy / Pull handle / Barre de tirage / Офисная ручка

Medos



SP

12





-N°: 114SP30050045

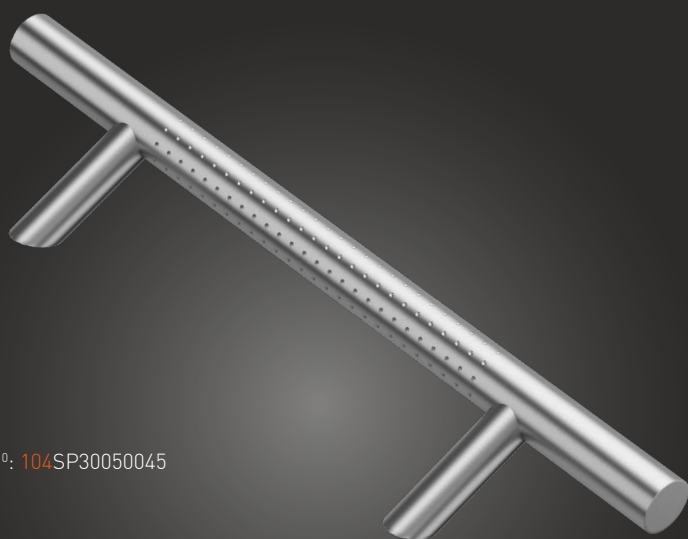

-N°: 104SP30050045

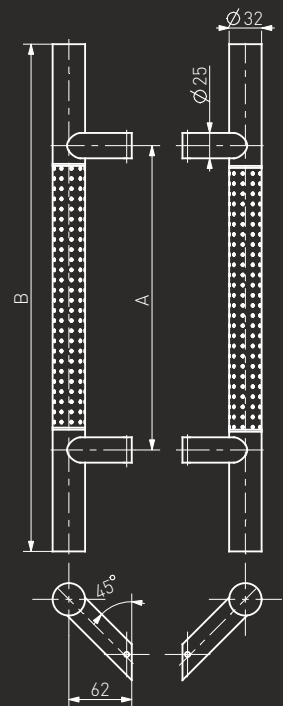

A	B
300	500
450	650
600	800
1200	1400

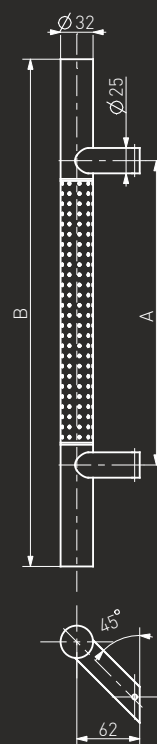

Pochwyt wymaga okresowej konserwacji
 Pull handle requires periodic maintenance
 Poignée de tirage exige une conservation régulière
 Офисный ухват требует регулярного ухода

Pochwyt ze stali nierdzewnej "SP" (INOX)

Nakrapiany / Spotted / Pointillée / С фрезерованной поверхностью в виде точек

Pochwyt drzwiowy / Pull handle / Barre de tirage / Офисная ручка

Medos

CS





-N°: 114CS30050045

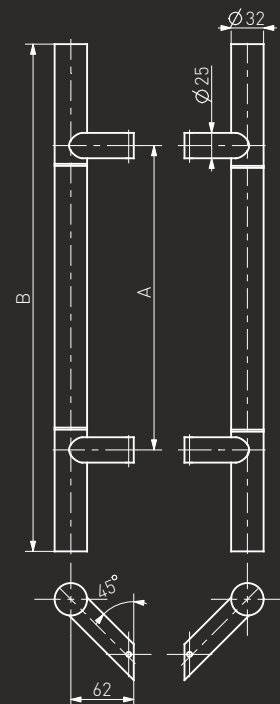

A	B
300	500
450	650
600	800
1200	1400

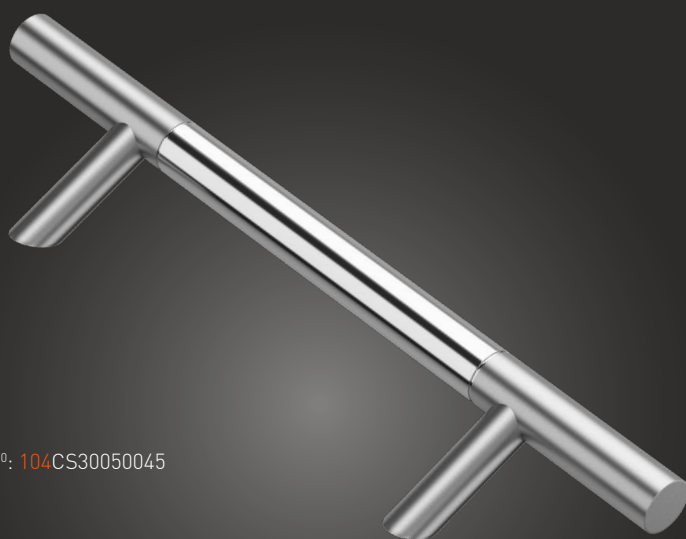

-N°: 104CS30050045

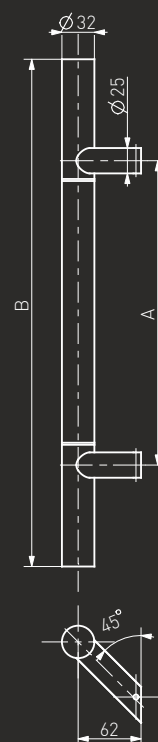

Pochwyt wymaga okresowej konserwacji
 Pull handle requires periodic maintenance
 Poignée de tirage exige une conservation régulière
 Офисный ухват требует регулярного ухода

Pochwyt ze stali nierdzewnej "CS" (INOX)

Szczotkowany/polerowany / Brushed/polished / Brossée/polie / Шлифованная/полированная

Pochwyt drzwiowy / Pull handle / Barre de tirage / Офисная ручка

Medos



MA

-N°: 114MA30042245

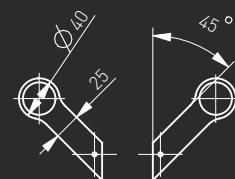
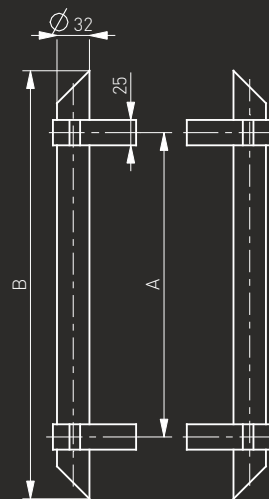

A	B
300	422
450	572
600	722
1200	1322

-N°: 104MA30042245

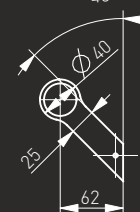
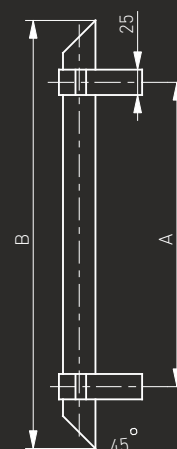
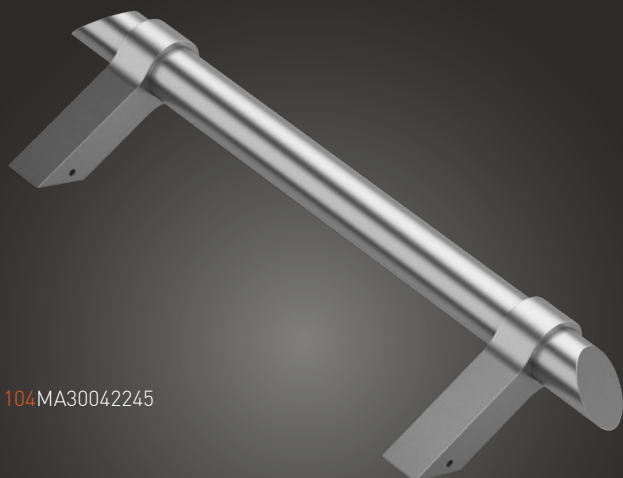

Pochwył wymaga okresowej konserwacji
Pull handle requires periodic maintenance
Poignée de tirage exige une conservation régulière
Офисный ухват требует регулярного ухода

Pochwył ze stali nierdzewnej "MA" (INOX)

Szczotkowany / Brushed / Brossée / Шлифованная

Pochwył drzwiowy / Pull handle / Barre de tirage / Офисная ручка

Medos



SE



-N°: 114SE30039645

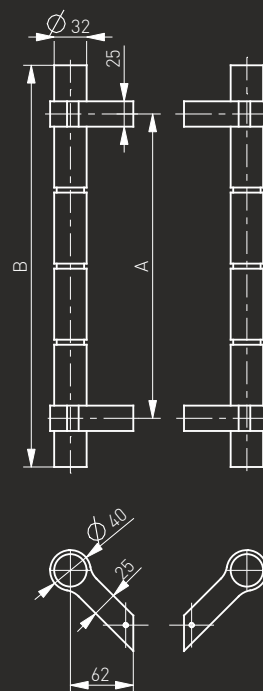

A	B
300	396
600	696
1200	1296

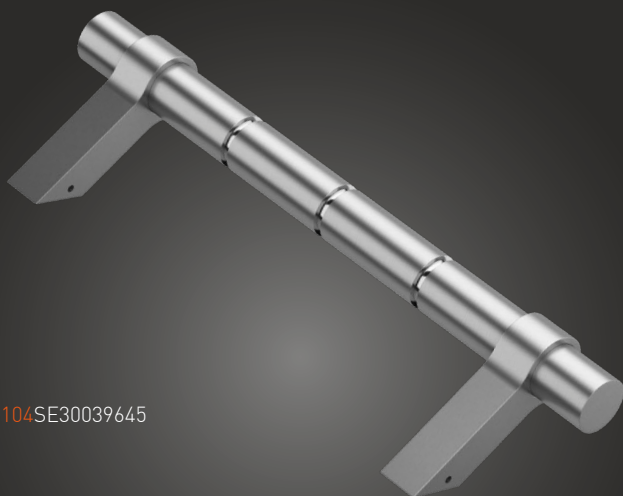

-N°: 104SE30039645

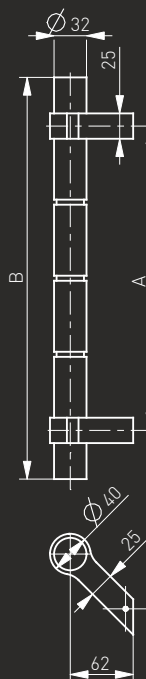

Pochwył wymaga okresowej konserwacji
 Pull handle requires periodic maintenance
 Poignée de tirage exige une conservation régulière
 Офисный ухват требует регулярного ухода

Pochwył ze stali nierdzewnej "SE" (INOX)

Szczotkowany / Brushed / Brossée / Шлифованная

Pochwył drzwiowy / Pull handle / Barre de tirage / Офисная ручка

Medos



WB





-Nº: 2x 104WB30051945

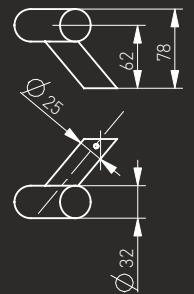
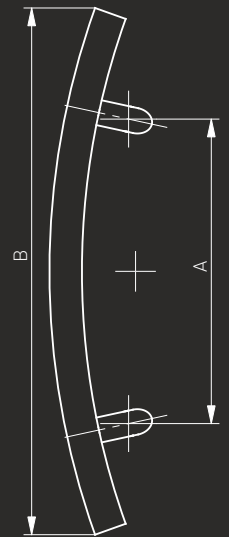

A	B
300	519
560	802

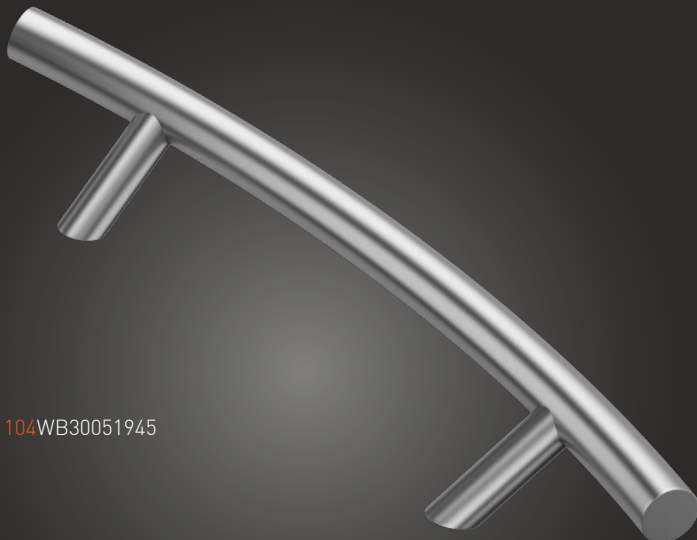

-Nº: 104WB30051945

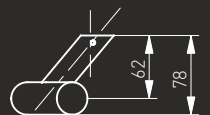
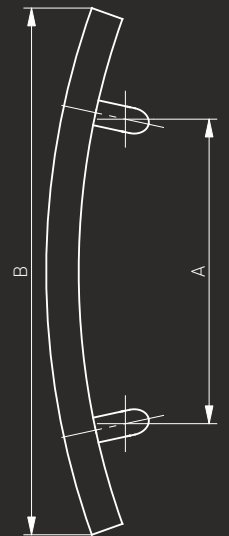

Pochwyt wymaga okresowej konserwacji
 Pull handle requires periodic maintenance
 Poignée de tirage exige une conservation régulière
 Офисный ухват требует регулярного ухода

Pochwyt ze stali nierdzewnej "WB" (INOX)

Szczotkowany / Brushed / Brossée / Шлифованная

Pochwyt drzwiowy / Pull handle / Barre de tirage / Офисная ручка

Medos

3



CW



-N^o: 114CW30050090

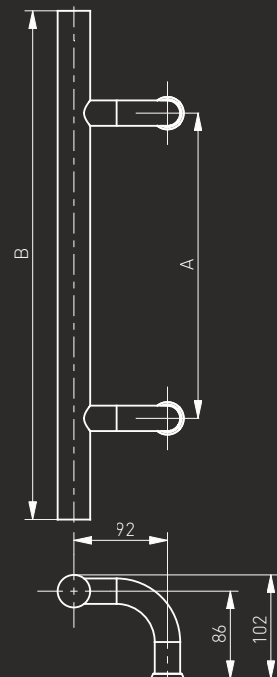

A	B
300	500
450	650
600	800
1200	1400
1300	1800

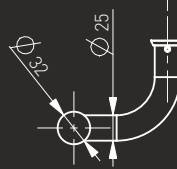

-N^o: 104CW30050090

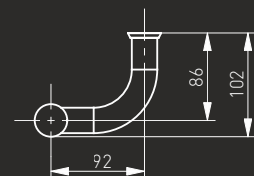
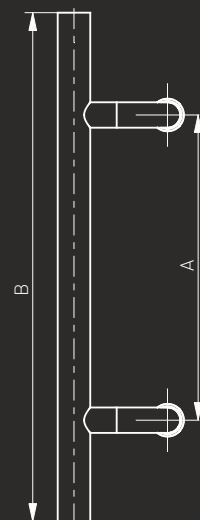

Pochwyt wymaga okresowej konserwacji
 Pull handle requires periodic maintenance
 Poignée de tirage exige une conservation régulière
 Офисный ухват требует регулярного ухода

Pochwyt ze stali nierdzewnej "CW" (INOX)

Szczotkowany / Brushed / Brossée / Шлифованная

Pochwyt drzwiowy / Pull handle / Barre de tirage / Офисная ручка

Medos



PR





-N^o: 114PR30050045

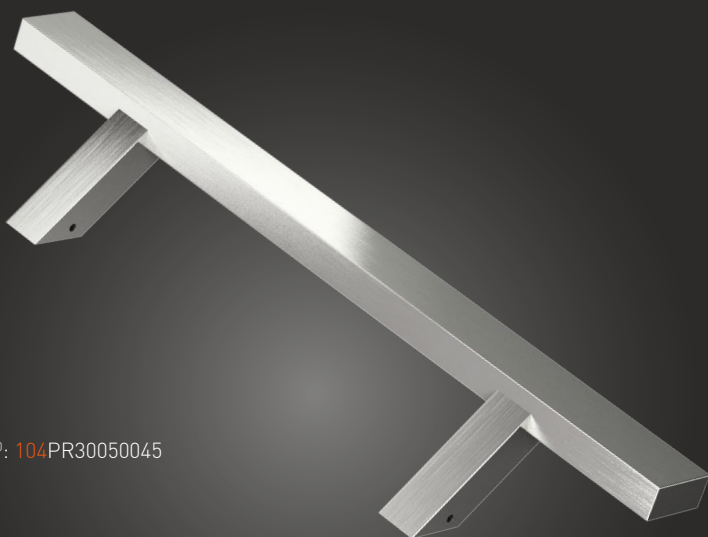

-N^o: 104PR30050045



Pochwył na wymiar
Custom Sized Stainless Steel Pull Handles
Poignées de tirage inox sur mesure
Офисная ручка под размер



Pochwył wymaga okresowej konserwacji
Pull handle requires periodic maintenance
Poignée de tirage exige une conservation régulière
Офисный ухват требует регулярного ухода

A	B
300	500
450	650
600	800
800	1000
1000	1200
1200	1400
1200	1600
1300	1800

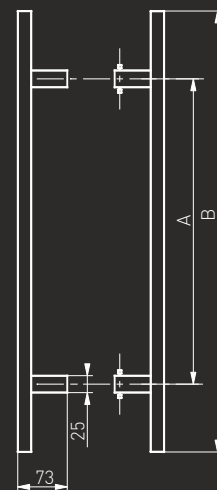

45°

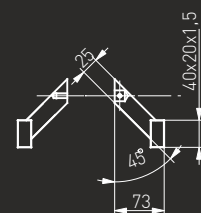

90°

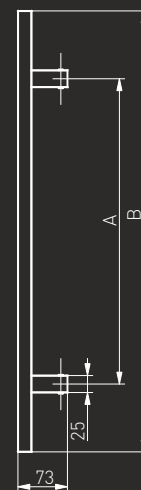
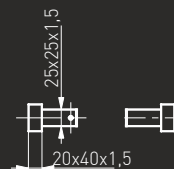

Pochwył ze stali nierdzewnej "PR" (INOX)

Szczotkowany / Brushed / Brossée / Шлифованная

Pochwył drzwiowy / Pull handle / Barre de tirage / Офисная ручка

Medos



PR9005S





-Nº: 2x 104PR300500459005

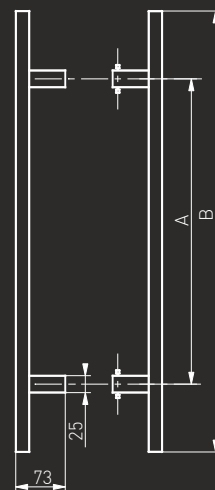

A	B	∠
300	500	45°, 90°
600	800	45°
800	1000	45°
1000	1200	45°
1200	1400	45°
1300	1800	45°

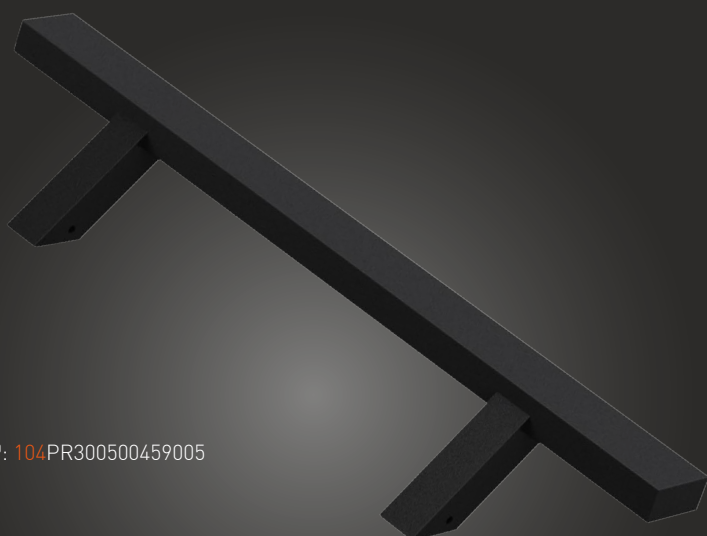

-Nº: 104PR300500459005

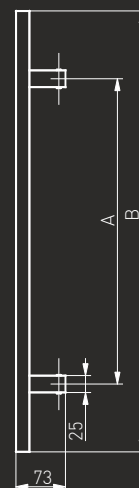

Pochwyt wymaga okresowej konserwacji
 Pull handle requires periodic maintenance
 Poignée de tirage exige une conservation régulière
 Офисный ухват требует регулярного ухода



Pochwyt ze stali nierdzewnej "PR9005S" (INOX)

Lakierowany / Varnished / Laqué / Лакированный

Pochwyt drzwiowy / Pull handle / Barre de tirage / Офисная ручка

Medos

4

KW





-N^o: 114KW30050045

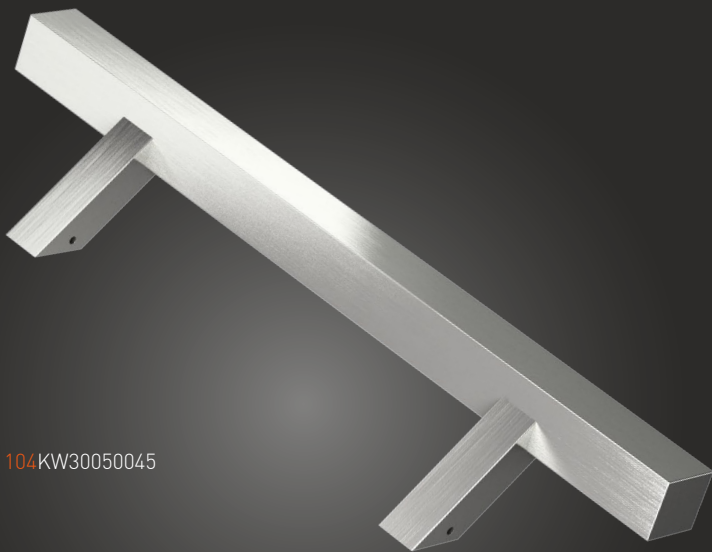

-N^o: 104KW30050045

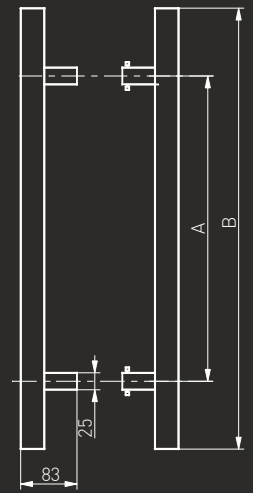

45°

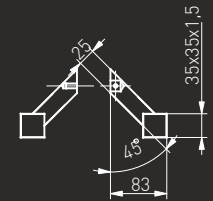

90°

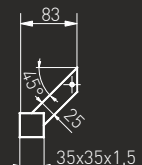
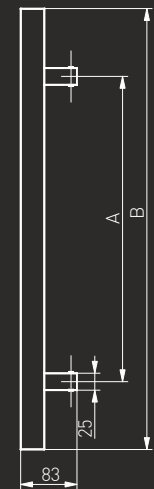
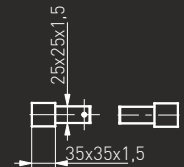

A	B
300	500
450	650
600	800
800	1000
1000	1200
1200	1400
1200	1600
1300	1800



Pochwył na wymiar
Custom Sized Stainless Steel Pull Handles
Poignées de tirage inox sur mesure
Офисная ручка под размер



Pochwył wymaga okresowej konserwacji
Pull handle requires periodic maintenance
Poignée de tirage exige une conservation régulière
Офисный ухват требует регулярного ухода

Pochwył ze stali nierdzewnej "KW" (INOX)

Szczotkowany / Brushed / Brossée / Шлифованная

Pochwył drzwiowy / Pull handle / Barre de tirage / Офисная ручка

Medos



Paris



-N^o: 114P30050045B

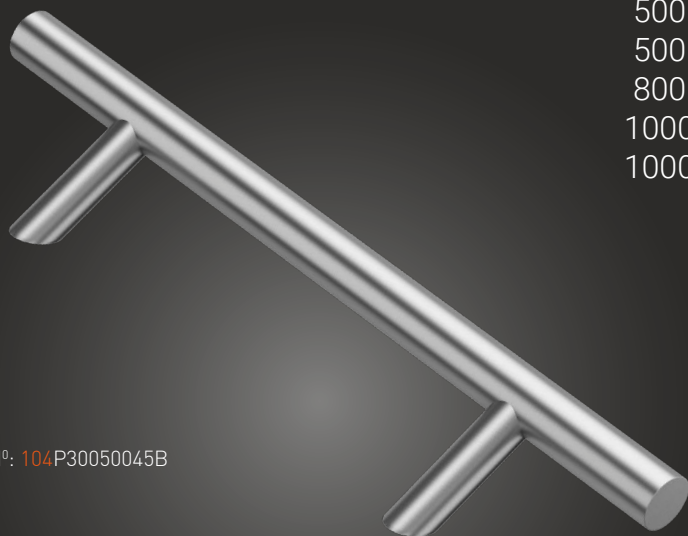

-N^o: 104P30050045B

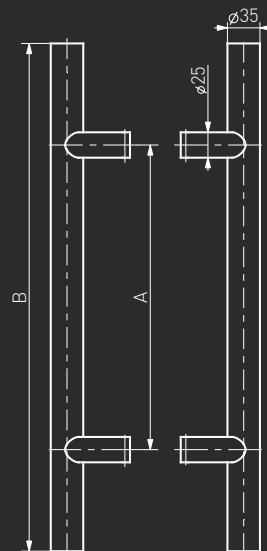

45°

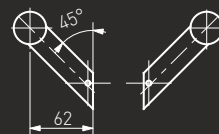

90°



A	B
300	500
450	650
500	800
500	1000
800	1200
1000	1500
1000	1700

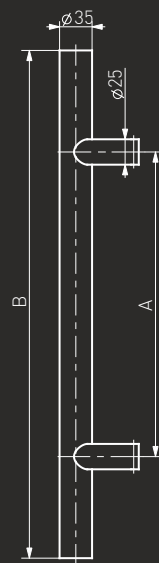

45°



90°

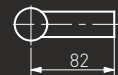

F1 - BD

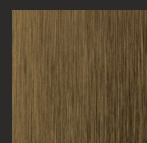

F4 - BD



F6 - BD (INOX)



F9005 - BD



Pochwył wymaga okresowej konserwacji
 Pull handle requires periodic maintenance
 Poignée de tirage exige une conservation régulière
 Офисный ухват требует регулярного ухода

Pochwył aluminiowy "Paris"

Anodowany - Szczotkowany / Anodized - Brushed / Anodisation - Brossée / Анодирование - Шлифованная

Pochwył drzwiowy / Pull handle / Barre de tirage / Офисная ручка

Medos



Lisbon

Paris



-N^o: 114L30050045B

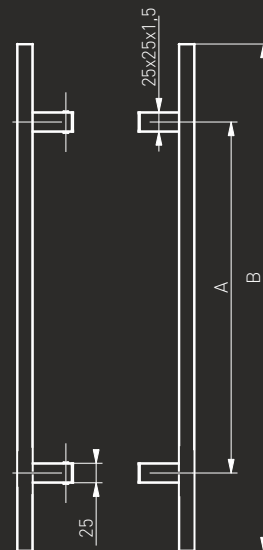

45°

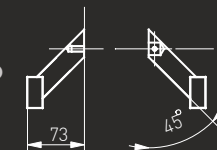

90°

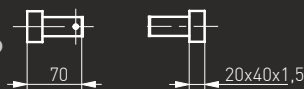

F1 - BD

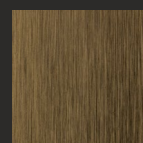

F4 - BD



F6 - BD (INOX)



F9005 - BD

A	B
300	500
450	650
500	800
500	1000
800	1200
1000	1500
1000	1700

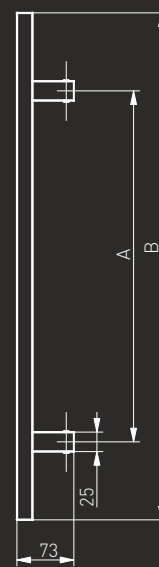

45°

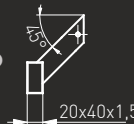

90°



Pochwył wymaga okresowej konserwacji
 Pull handle requires periodic maintenance
 Poignée de tirage exige une conservation régulière
 Офисный ухват требует регулярного ухода

Pochwył aluminiowy "Lisbon"

Anodowany - Szczotkowany / Anodized - Brushed / Anodisation - Brossée / Анодирование - Шлифованная

Pochwył drzwiowy / Pull handle / Barre de tirage / Офисная ручка

Medos

Madrid





-N°: 114M30050045B

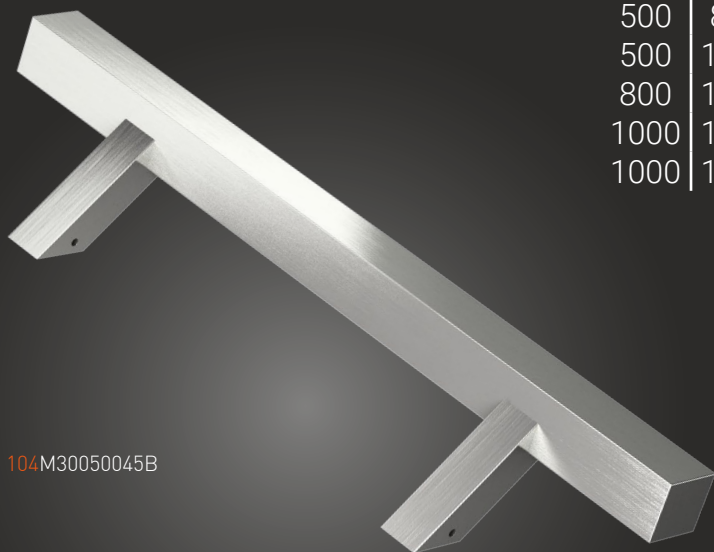

-N°: 104M30050045B

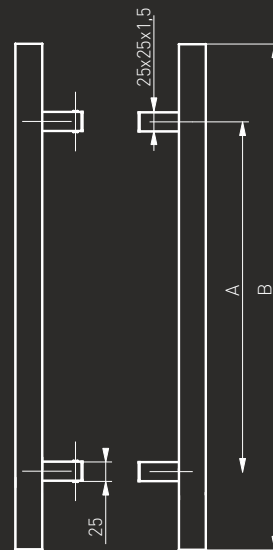

45°

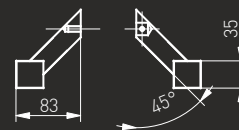

90°



A	B
300	500
450	650
500	800
500	1000
800	1200
1000	1500
1000	1700



F1 - BD

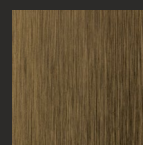

F4 - BD



F6 - BD (INOX)



F9005 - BD

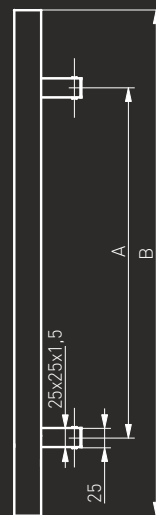

45°

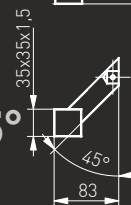

90°

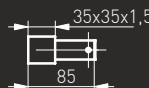

Pochwył wymaga okresowej konserwacji
 Pull handle requires periodic maintenance
 Poignée de tirage exige une conservation régulière
 Офисный ухват требует регулярного ухода

Pochwył aluminiowy "Madrid"

Anodowany - Szczotkowany / Anodized - Brushed / Anodisation - Brossée / Анодирование - Шлифованная

Pochwył drzwiowy / Pull handle / Barre de tirage / Офисная ручка

Medos



Prostokątny

IV





-Nº: 114SILV3001

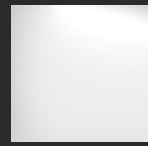
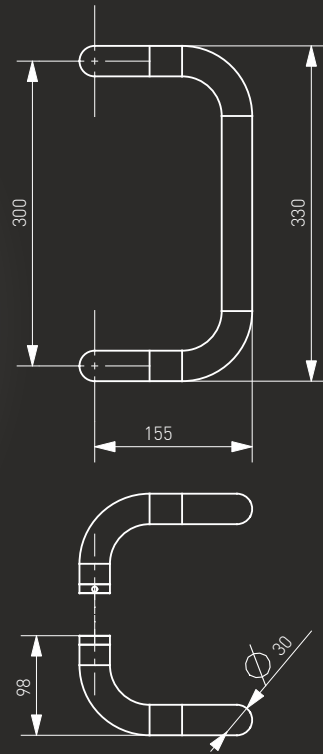

RAL 9016



RAL 8019

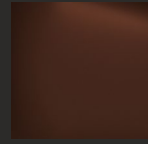

RAL 8017

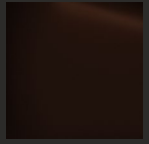

RAL 8077

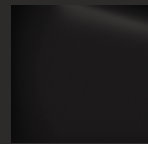

RAL 9005 MAT



RAL 8003

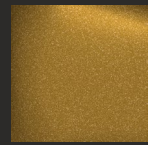

GOLD



SILVER

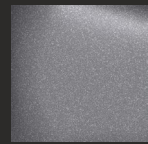

TITAN



SATIN

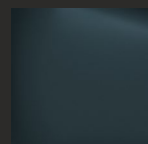

RAL 7016 MAT

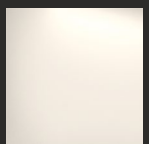

RAL 9001



-Nº: 104SILV3001

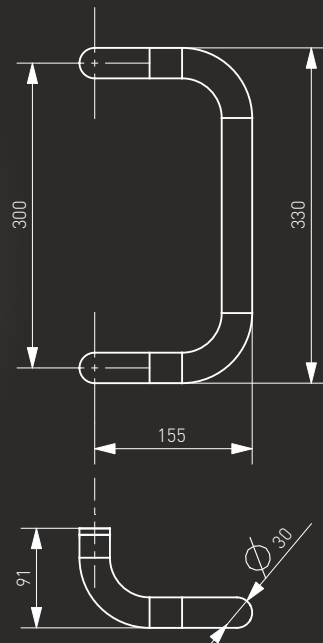

Pochwyt aluminiowy "Prostokątny"

Pochwyt drzwiowy / Pull handle / Barre de tirage / Офисная ручка

Medos

Trojkatny



-N^o: 114SILV3002

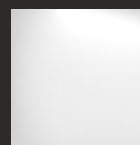
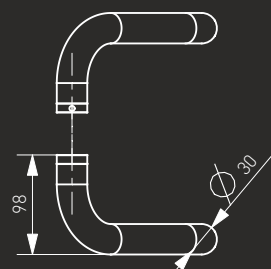
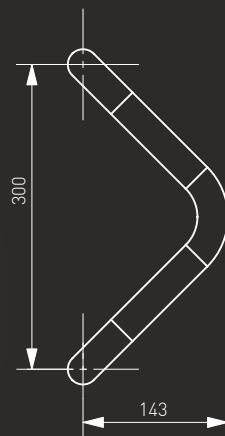

RAL 9016

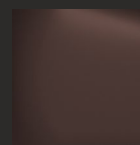

RAL 8019

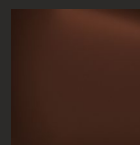

RAL 8017

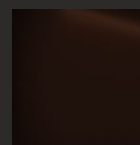

RAL 8077

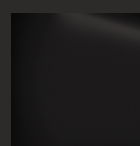

RAL 9005 MAT

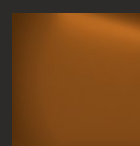

RAL 8003

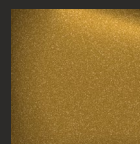

GOLD

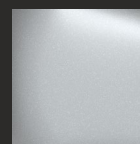

SILVER



TITAN

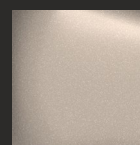

SATIN

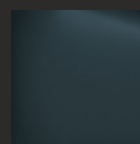

RAL 7016 MAT

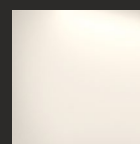

RAL 9001

-N^o: 104SILV3002

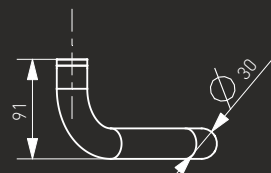
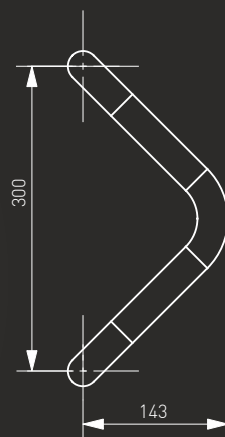

Pochwył aluminiowy "Trójkątny"

Pochwył drzwiowy / Pull handle / Barre de tirage / Офисная ручка

Medos

V

Prosty



-N^o: 114SILV3003

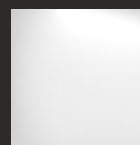
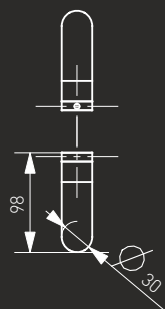
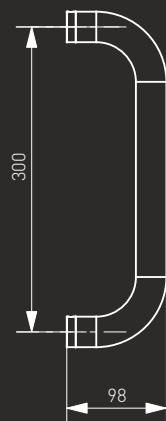

RAL 9016

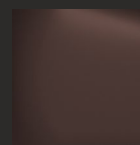

RAL 8019

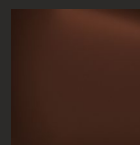

RAL 8017

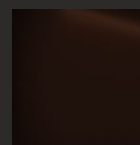

RAL 8077

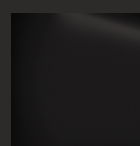

RAL 9005 MAT

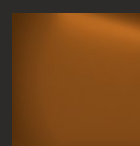

RAL 8003

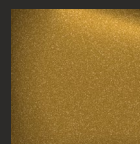

GOLD

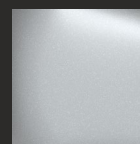

SILVER

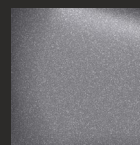

TITAN

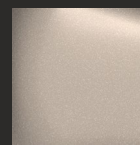

SATIN

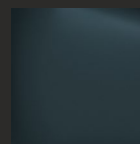

RAL 7016 MAT

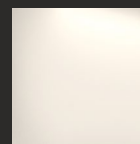

RAL 9001

-N^o: 104SILV3003

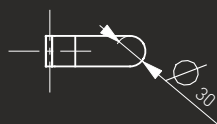
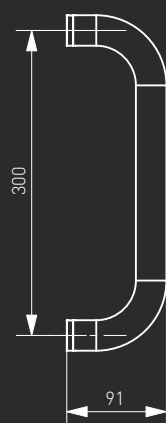

Pochwyt aluminiowy "Prosty"

Pochwyt drzwiowy / Pull handle / Barre de tirage / Офисная ручка

Medos

Owalny





-Nº: 114SILV3004

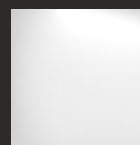
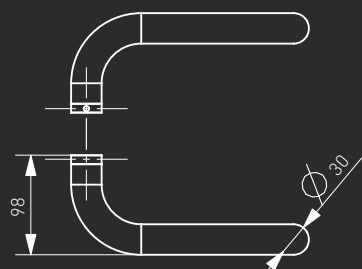
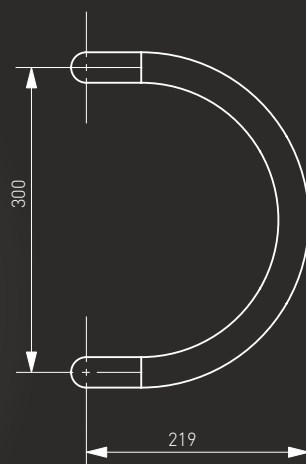

RAL 9016

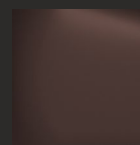

RAL 8019

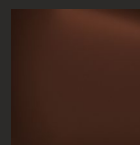

RAL 8017

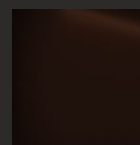

RAL 8077

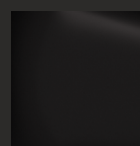

RAL 9005 MAT

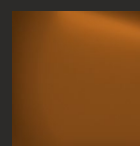

RAL 8003

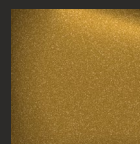

GOLD

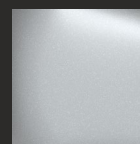

SILVER

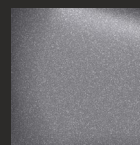

TITAN

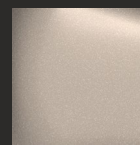

SATIN

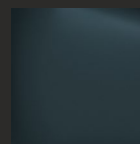

RAL 7016 MAT

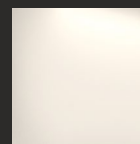

RAL 9001



-Nº: 104SILV3004

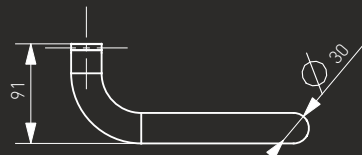
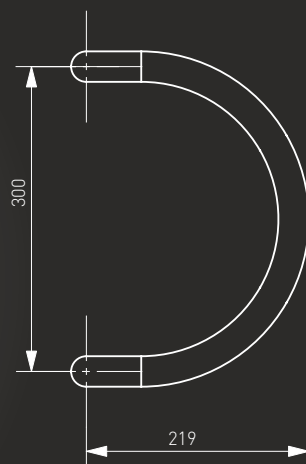

Pochwyt aluminiowy "Owalny"

Pochwyt drzwiowy / Pull handle / Barre de tirage / Офисная ручка

-N^o: 50S292F6BWS

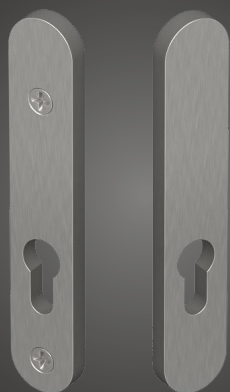

L
72
92

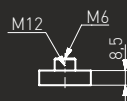
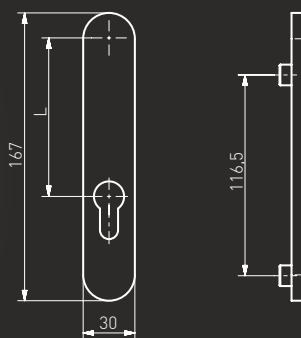

F1 - BD

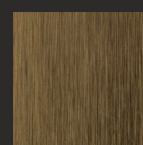

F4 - BD



F6 - BD (INOX)



F9005 - BD

-N^o: 60SPLUS2F6BWS

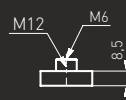
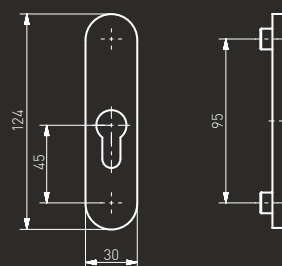

Szyld aluminiowy "Sofia"

Szyld drzwiowy / Door rosette / Rosace / Накладка под цилиндр

-Nº: 70R292F6BWS

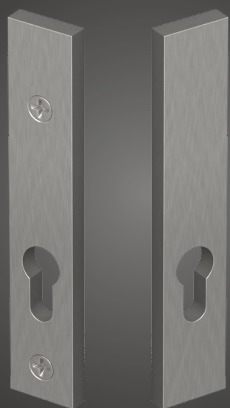

$\frac{L}{72}$
92

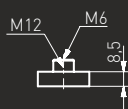
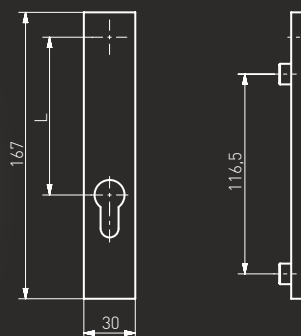

F1 - BD

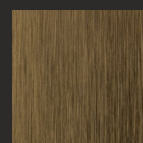

F4 - BD

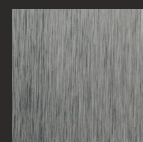

F6 - BD (INOX)



F9005 - BD

-Nº: 80RPLUS2F6BWS

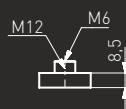
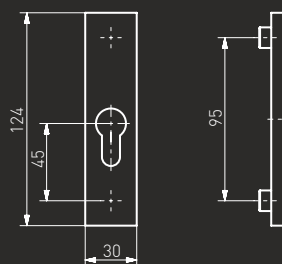

Szyld aluminiowy "Riga"

Szyld drzwiowy / Door rosette / Rosace / Накладка под цилиндр

-N°: 151INOX0000

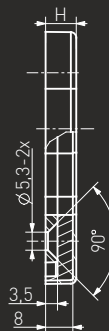
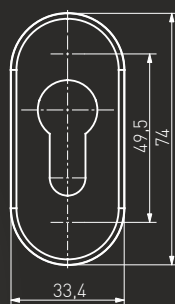

H
6,5
9

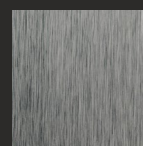

INOX



RAL9005S

-N°: 150INOX0000

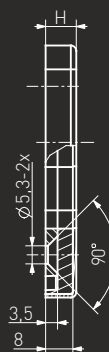
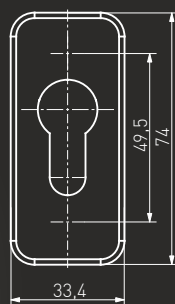

Szyld ze stali nierdzewnej (INOX)

-N°: 151SILV0000

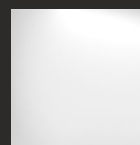
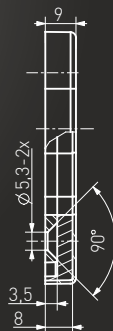
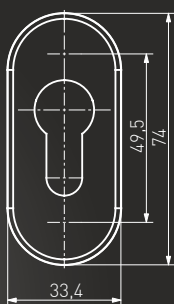

RAL 9016

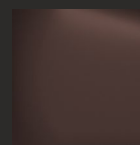

RAL 8019

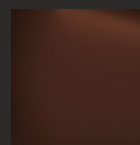

RAL 8017

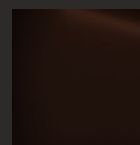

RAL 8077

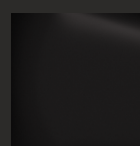

RAL 9005 MAT

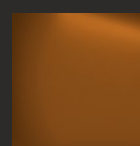

RAL 8003

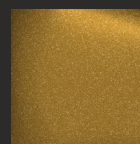

GOLD

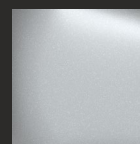

SILVER

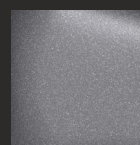

TITAN

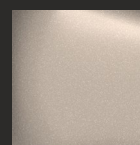

SATIN

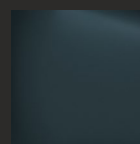

RAL 7016 MAT

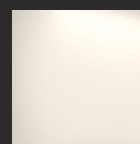

RAL 9001

-N°: 150SILV0000

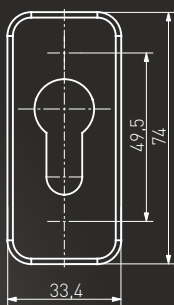

Szyld aluminiowy

Szyld drzwiowy / Door rosette / Rosace / Накладка под цилиндр

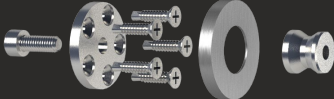
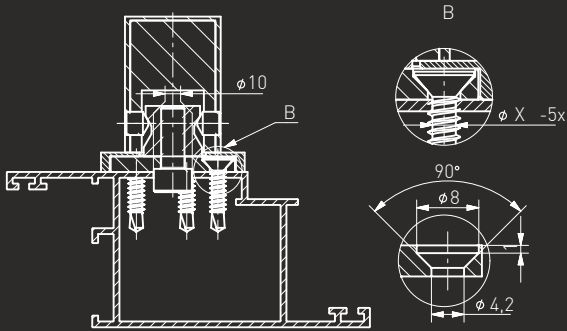
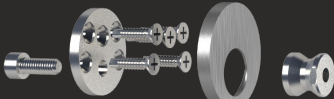
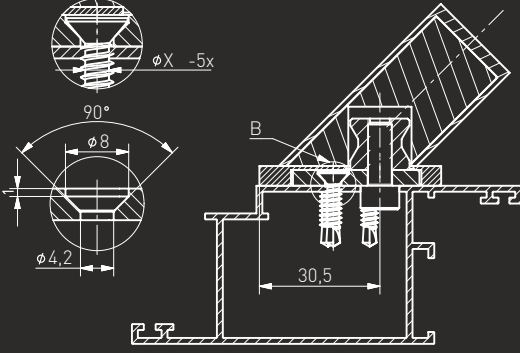
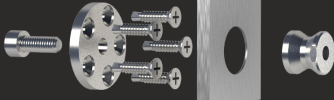
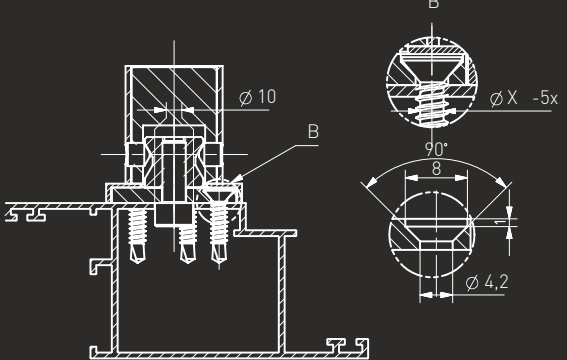
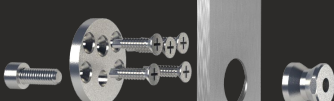
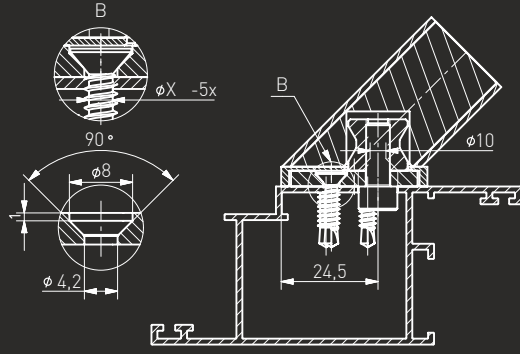

Mocowania do pochwytów ze stali nierdzewnej

Stainless steel pull handles fixing sets / Kit de fixation pour les barres de tirage en INOX / Крепление для ручек из нержавеющей стали

Mocowanie na płytce Fixing set Fixation Крепление	Opis Description Description Описание	Index -N°	Rys. techniczny Technical drawing Fiche technique Чертеж
	<p>INOX O-90</p> <p>Obsługiwane pochwyt Compatible models Barres de tirage prises en charge Подходит для ручек SS / CW</p> <p>Kąt mocowania Mounting angle Position de montage Угол крепления 90°</p>	<p>ALU 10409002</p>	
	<p>INOX O-45</p> <p>Obsługiwane pochwyt Compatible models Barres de tirage prises en charge Подходит для ручек SS / SP / CS / WB</p> <p>Kąt mocowania Mounting angle Position de montage Угол крепления 45°</p>	<p>ALU 10404502</p>	
	<p>INOX KP-90</p> <p>Obsługiwane pochwyt Compatible models Barres de tirage prises en charge Подходит для ручек KW / PR</p> <p>Kąt mocowania Mounting angle Position de montage Угол крепления 90°</p>	<p>ALU 104KP9002</p>	
	<p>INOX KP-45</p> <p>Obsługiwane pochwyt Compatible models Barres de tirage prises en charge Подходит для ручек KW / PR / SE / MA</p> <p>Kąt mocowania Mounting angle Position de montage Угол крепления 45°</p>	<p>ALU 104KP4502</p>	



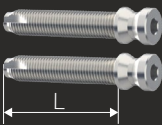
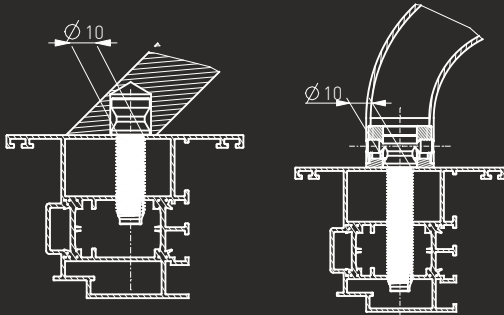

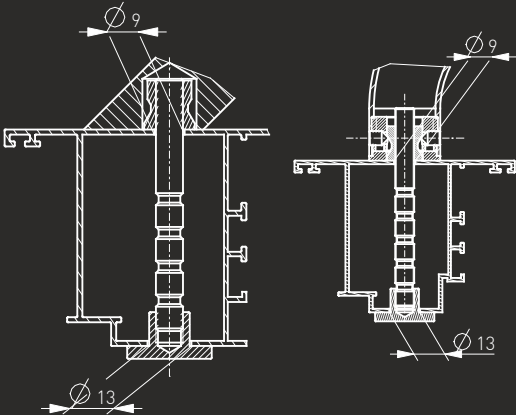
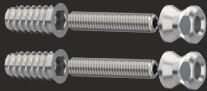
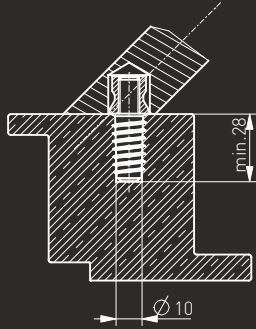
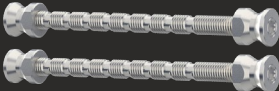
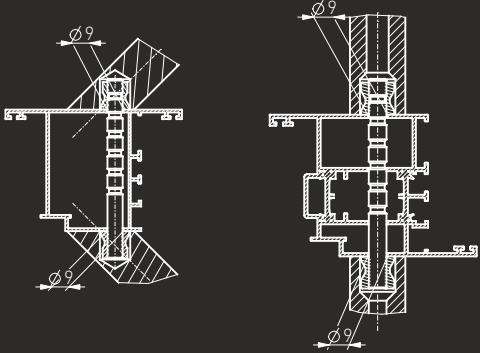
Mocowania do pochwytów ze stali nierdzewnej

Stainless steel pull handles fixing sets / Kit de fixation pour les barres de tirage en INOX / Крепление для ручек из нержавеющей стали

Mocowanie Fixing set Fixation Крепление	Opis Description Description Описание	Index -N°	Rys. techniczny Technical drawing Fiche technique Чертеж
	<p>Jednostronna turbośruba samogwintująca</p> <p>Single side self-tapping screw</p> <p>Vis autotaraudeuses pour les unilatéraux</p> <p>Саморезы для теплового профиля</p> <p>45° / 90°</p>	<p>10400003500 10400004500 10400005500</p>	
	<p>Jednostronne mocowanie przelotowe</p> <p>Single side inside-out fixing set</p> <p>Vis de fixation à l'envers pour les unilatéraux</p> <p>Крепление для односторонней установки</p> <p>45° / 90°</p>	<p>10400000000</p>	
	<p>Jednostronne mocowanie do drzwi drewnianych i stalowych</p> <p>Single side wooden door fixing set</p> <p>Kit de fixation pour les portes en bois pour les unilatéraux</p> <p>Одностороннее крепление к дереву</p> <p>45° / 90°</p>	<p>10400000012</p>	
	<p>Dwustronne mocowanie do pochwytów jednostronnych</p> <p>Double sided fixing set for single side stainless steel pull handles</p> <p>Kit de fixation pour créer un barre de tirage bilatéral de deux unilatéraux</p> <p>Двухстороннее крепление для установки односторонних ручек</p> <p>45° / 90°</p>	<p>11400000010</p>	

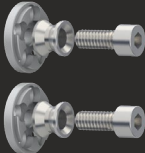
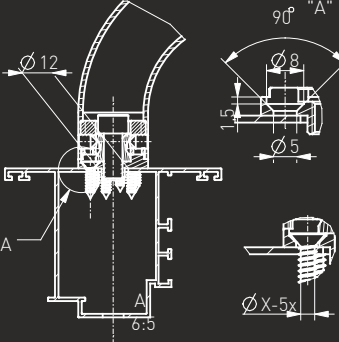
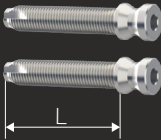
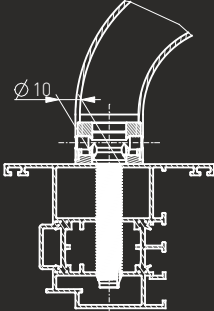
Mocowania do pochwytów aluminiowych

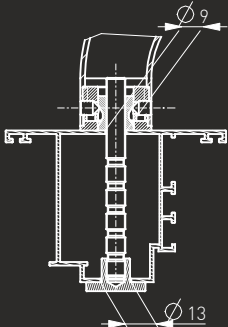
Aluminum pull handles fixing sets / Kit de fixation pour les barres de tirage en aluminium / Крепление для алюминиевых ручек

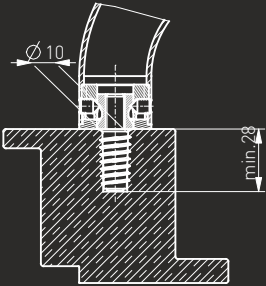
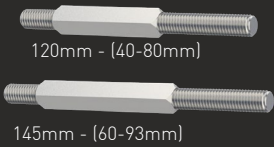
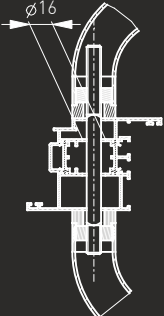
Mocowanie Fixing set Fixation Крепление	Opis Description Description Описание	Index -N°	Rys. techniczny Technical drawing Fiche technique Чертеж
	<p>Talerzyk - jednostronne mocowanie pochwytów aluminiowych</p> <p>Fixing Plate – single side fixing set for aluminum pull handles</p> <p>Plaque de fixation pour les barres unilatéraux en aluminium</p> <p>Крепление для односторонних алюминиевых ручек - пластина</p>	10400000002	
	<p>Jednostronna turbośruba samogwintująca</p> <p>Single side self-tapping screw</p> <p>Vis autotaraudeuses pour les unilatéraux</p> <p>Саморезы для теплого профиля</p>	<p>10400003500 10400004500 10400005500</p>	
	<p>Jednostronne mocowanie przelotowe</p> <p>Single side inside-out fixing set</p> <p>Vis de fixation à l'envers pour les unilatéraux</p> <p>Крепление для односторонней установки</p>	<p>10400000000 F1: 104F1 F4: 104F4 F6: 104F6 F9005: 104F9005 RAL9005S: 1049005S</p>	
	90°		
	<p>Jednostronne mocowanie do drzwi drewnianych i stalowych</p> <p>Single side wooden door fixing set</p> <p>Kit de fixation pour les portes en bois pour les unilatéraux</p> <p>Одностороннее крепление к дереву</p>	10400000012	
	<p>Śruba rzymska - dwustronne mocowanie pochwytów aluminiowych</p> <p>Roman screw - double-sided fixing set for aluminum pull handles</p> <p>Tendeur à vis- kit de fixation pour les barres de tirage bilatéraux en aluminium</p> <p>Крепление для двухсторонних алюминиевых ручек</p>	<p>11400000000 11400000010</p>	
120mm - (40-80mm)			
145mm - (60-93mm)			
	90°		



DZIAŁ SPRZEDAŻY KRAJOWEJ

Andrzej Lewoń

Kierownik Działu Marketingu i Handlu - Polska
Tel. +48 56 691 20 59
Kom. +48 513 193 938
andrzej@medos.pl

Zbigniew Mysza

Specjalista ds. Marketingu i Handlu
Tel. +48 56 691 20 75
Kom. +48 609 023 372
zbyszek@medos.pl

Tomasz Poniąkowski

Specjalista ds. Marketingu i Handlu
Tel. +48 56 691 20 64
Kom. +48 508 186 242
tomek@medos.pl

Przemysław Lasowski

Specjalista ds. Marketingu i Handlu
Tel. +48 56 691 20 75
Kom. +48 601 277 142
przemek@medos.pl

Marcin Mątewski

Specjalista ds. Marketingu i Handlu
Tel. +48 56 691 20 58
Kom. +48 607 236 009
marcin.m@medos.pl

Karol Przybylski

Specjalista ds. Marketingu i Handlu
Tel. +48 56 691 20 59
Kom. +48 505 079 162
karol.p@medos.pl

Krystian Konopacki

Specjalista ds. Marketingu i Handlu
Tel. +48 56 691 20 59
Kom. +48 693 013 401
krystian.k@medos.pl

Błażej Gawroński

Specjalista ds. Marketingu i Handlu
Tel. +48 56 662 74 29
Kom. +48 603 030 742
blazej.g@medos.pl



INTERNATIONAL SALES

Łukasz Napieralski

International Sales Director
Tel. +48 56 691 20 56
Mob. +48 515 248 576
Fax +48 56 691 20 50
lukasz@medos.pl



EN



ES



RU

Adam Szulc

Export Manager
Tel. +48 56 691 30 97
Mob. +48 609 318 148
Fax +48 56 691 20 50
as@medos.pl



EN

Andrzej Mojsiewicz

Export Manager
Tel. +48 56 691 20 70
Mob. +48 502 718 288
andrzej.m@medos.pl



RU



LT

Grażyna Kierska

Export Manager
Tel. +48 56 662 74 14
Mob. +48 607 856 654
gk@medos.pl



FR



IT



EN



ES

Ewa Bartoszevska

Export Manager
Mob. +48 601 945 737
ewa.b@medos.pl



RU



EN



 Medos

MEDOS
ul. Magazynowa 3
86-200 Chełmno / Polska

NIP: 875-10-02-162
REGON: 870568014

www.medos.pl

tel.: +48 (56) 56 691 20 79
fax: +48 (56) 691 20 50



Inn000564